

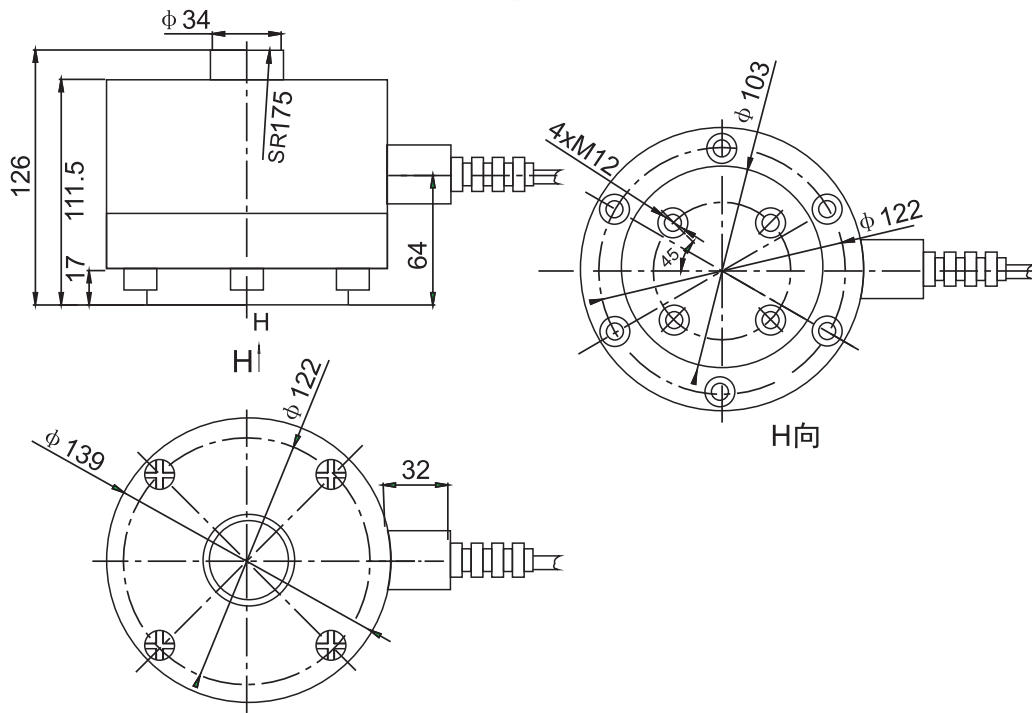

WQH Loadcell

WQH

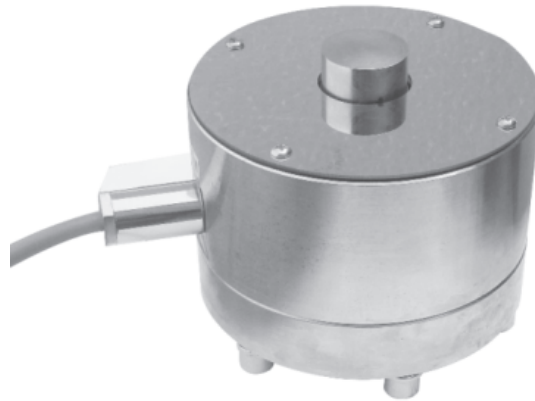

Axle-load scale, warehouse scale testing equipment , Truck Scale

TECHNICAL PARAMETER | OAP version 4Wires:Exc+(Blue);Exc-(Black);Sig+(White);Sig-(Red)

Rated capacities(Emax)	20t	Temperature range, compensated	-10°C~+40°C
Sensitivity	2.0±0.005mV/V	Temperature range, operating	-30~+70°C
Total error	±0.05%F.S	Maximum safe overload	150%F.S
Creep error (30min)	±0.05%F.S	Ultimate overload	200%F.S
Zero balance	±0.05%F.S	Excitation, recommended	10~12V DC
TC ZERO	±0.05%F.S/10°C	Excitation, maximum	15V DC
TC SPAN	±0.05%F.S/10°C	Protection class	IP67
Input resistance	750±10Ω	Construction	Alloy Steel
Output resistance	703±3Ω	Cable	Length:8m Diameter: φ 8mm
Insulation resistance	≥5000MΩ		